

UV CURABLE PRINT SOLUTION

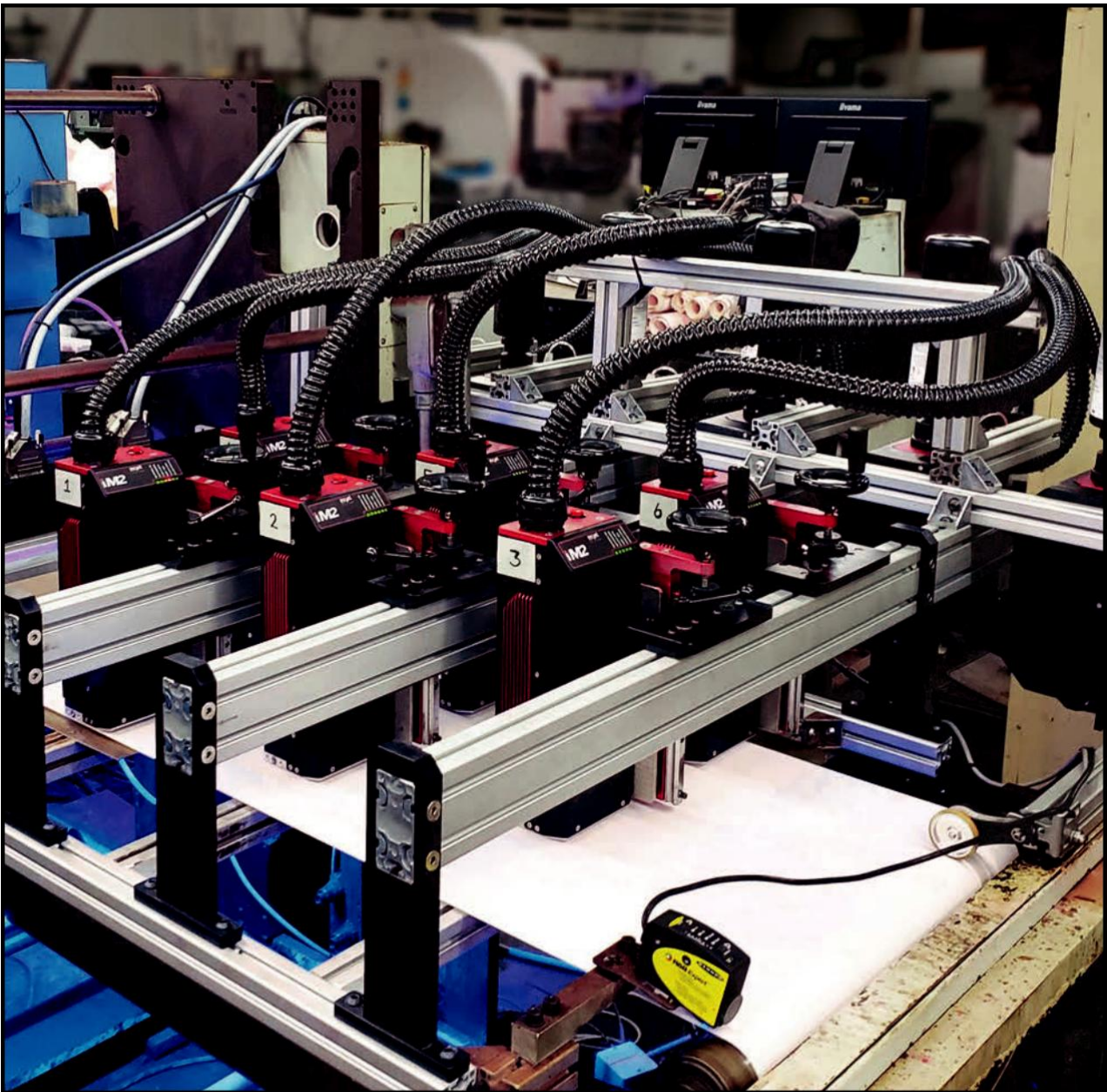

2.1" UV Curable Inkjet Solution

The high resolution iM2 printer provides a versatile, cost-effective solution to meet the need for variable data printing on a range of coated and uncoated substrates. Capable of printing addresses, barcodes, 2D codes, QR codes, numbering, logos and graphics, the iM2 is suitable for mailing and addressing applications, as well as labels, tickets, security, plastic cards and business form applications.

The very small footprint and modular design of the iM2 means that it is easily and quickly integrated into mailing lines, webs and card lines. With all the printer electronics and ink delivery systems built into the Printhead assembly, it is designed for maximum uptime.

One print solution, multiple applications

NUMBERING

Sequential numbers can be printed almost anywhere on a sheet or form and can be positioned horizontally or vertically. The iM2's high speed capabilities and crisp printing allow for perfect numbering in applications such as ticketing, lottery tickets and much more. At speeds in excess of 1000 feet per minute the iM2 is more than qualified to produce high efficiency prints.



PHARMA

The high resolution iM2 printer provides a versatile, cost-effective solution to meet the need for variable data printing on a range of coated and uncoated substrates. Printing with UV curable inks, all marking is crystal clear, highly durable and permanent, ensuring that key codes are always presented perfectly every time, whether for aesthetic or regulatory reasons.



CARD PRINTING

The iM2, with its 2.1" print width, is optimized for printing cards utilizing its multiple drop capabilities to get the very best quality together with solid durability. The combination of sophisticated hardware and software allow the user to print barcodes from light to heavy, meeting all of today's changing requirements.

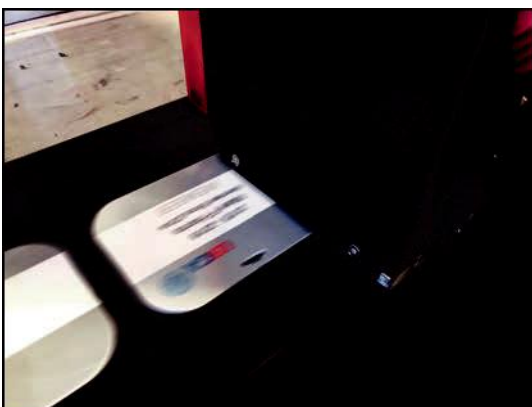

ADDRESSING

Reduced cost per mark, higher throughput and a wider variety of printable substrates give the iM2 print solutions a significant improvement over standard Thermal InkJet solutions in the Addressing marketplace. Matched with a proven I/O capability to control feeders, diverts, lamps and more, the iM2 is a solid performer.

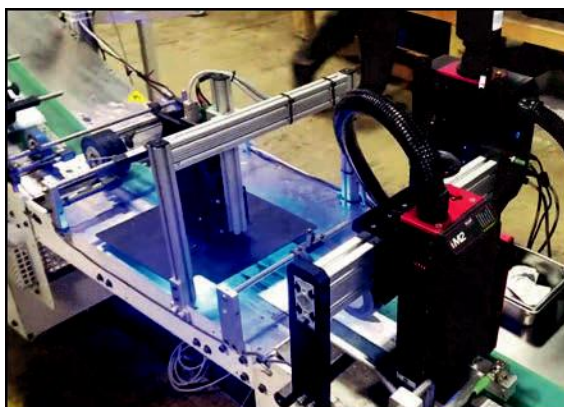

Outperforming the rest

A smaller footprint, higher throughput, lower costs and proven technologies, the iM2 is a solid performer in the graphics and mail markets. Its clean design, simple to operate interface and low maintenance process ensure a short learning curve and rapid implementation of any new installation.

HIGH QUALITY, HIGH SPEED

The iM2 supports up to a 600 dpi resolution giving you maximum quality at all times; there is little that cannot be printed with incredible sharpness.



For all your graphics and mail applications the iM2 is capable of ultra fast speeds to meet your productivity goals

Horizontal Resolution	Max Speed *	
	m/min	ft/min
600	137	450
300	274	900
150	356	1200

* speeds will vary with ink type and drop size

COMPACT SIZE

One of the key design mandates for the iM2 was a small footprint. Not only is the Printhead compact, so is the interface enclosure. For the first time, trying to find space on your equipment for bulky ink handling systems and print heads is no longer a concern.

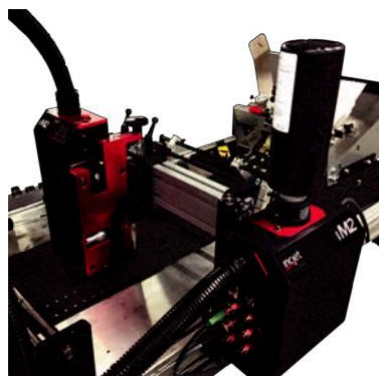

When utilizing multiple heads to get wider format capability this is especially important and the iM2 is a solid winner ensuring that whatever available space you have, the iM2 can fit!



The size of two business cards!

Minimal Footprint

Head:
315mm x 97mm x 165mm

Enclosure:
307mm x 145mm x 206mm

PREMIUM CAPABILITY, AT A LOWER COST

Print shops are constantly striving to remain competitive and differentiate themselves. An iM2 printer allows them to stay ahead of the market by implementing a highly cost effective print solution.

The iM2's initial cost is significantly lower than other solutions, but goes beyond just a hardware cost. Factoring in reduced maintenance, efficient use of inks, and reliability, the iM2 has a low Total Cost of Ownership..



This decrease in cost does not come at reduced capability or quality. The iM2 is a solid performer capable of very high throughputs and incredible clarity and durability of print.



EASE OF USE

With decades of experience in the graphics and mail markets, inc.jet has a wealth of knowledge to build on in developing print solutions that are simple to integrate and easy to operate. In fact, the Piezo based iM2 is as easy to use as a TIJ based printer.



Start up—Print ready can be achieved within five minutes, and job changeover is possible within seconds.

Print head purging—With print head mounting brackets moving between offline purging and printer ready position, fast make ready can be achieved effortlessly.

Power/Ink Empty LED

Indicates system power (green) and ink empty (red)

Ethernet Port

Communication port. TCP/IP 1000BaseT

Power On/Off

Soft on/off button

Sensor

12V PNP sensor signal

Encoder

12V PNP, dual channel 300 ppi encoder

Ink Supply

1 liter bottle, with non-spill cap

RFID Reader



Daisy Chain OUT

Carries sensor/encoder signals to additional print heads. (LVDS)

Daisy Chain IN

Takes sensor and encoder signals from additional print heads. (LVDS)

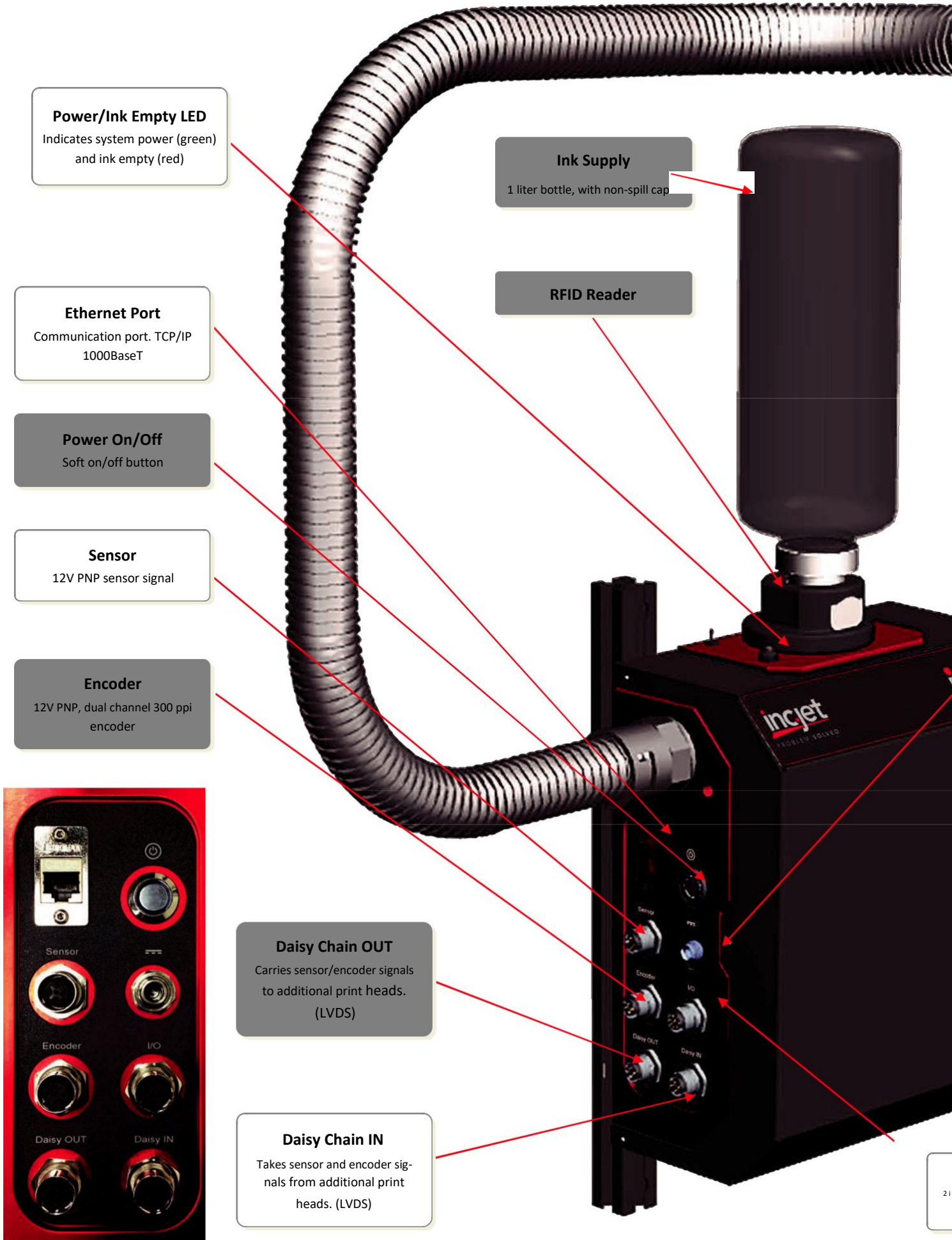

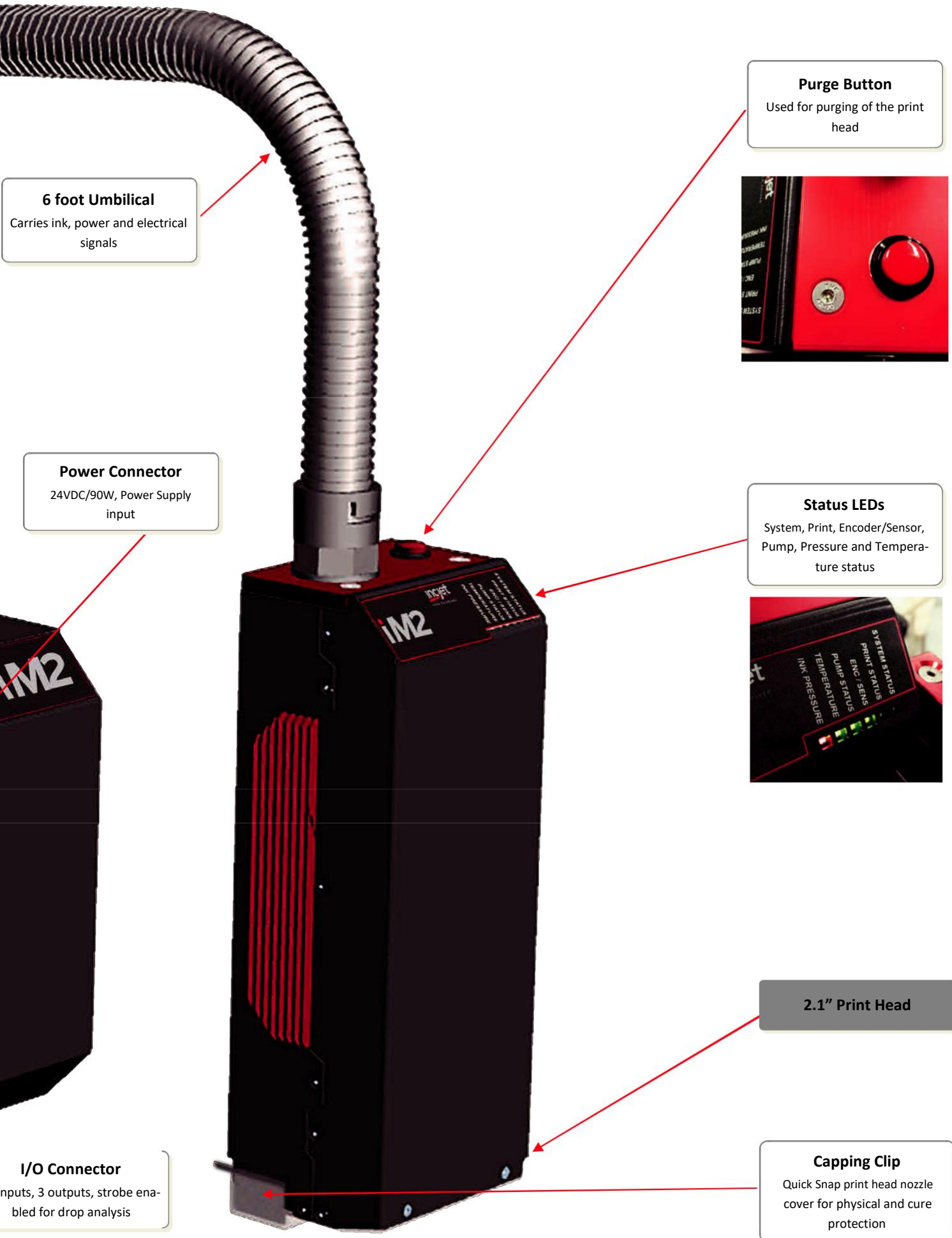

6 foot Umbilical

Carries ink, power and electrical signals

Purge Button

Used for purging of the print head

Power Connector

24VDC/90W, Power Supply input

Status LEDs

System, Print, Encoder/Sensor, Pump, Pressure and Temperature status

2.1" Print Head

I/O Connector

3 inputs, 3 outputs, strobe enabled for drop analysis

Capping Clip

Quick Snap print head nozzle cover for physical and cure protection

Groundbreaking Design

Simplicity is the key to the iM2 Design. From the Patented Ink Delivery system to the Electronics, Housing and interface connectors, the iM2 has been designed with ease of use in mind.

The iM2 uses a single pump and sensor to measure the ink pressure and to pump the ink directly from the supply to the print head as ink is being consumed while printing. Since there is no air reservoir for meniscus control there are no issues with ink flow, or flooding air sensors or valves (there are none).

With the head mounted directly to the manifold, the design greatly reduces the number of connections, tubes and failure points where leaks can occur.

The iM2 incorporates an integrated manifold heater that can preheat the ink before it reaches the head allowing the ink to flow better and operate much more reliably at higher speeds, resulting in less nozzle outs.

The head can be changed in the field without disassembling the ink delivery system and or any of the ink delivery connections. The system can be installed, primed and operational in less than 1 hour.

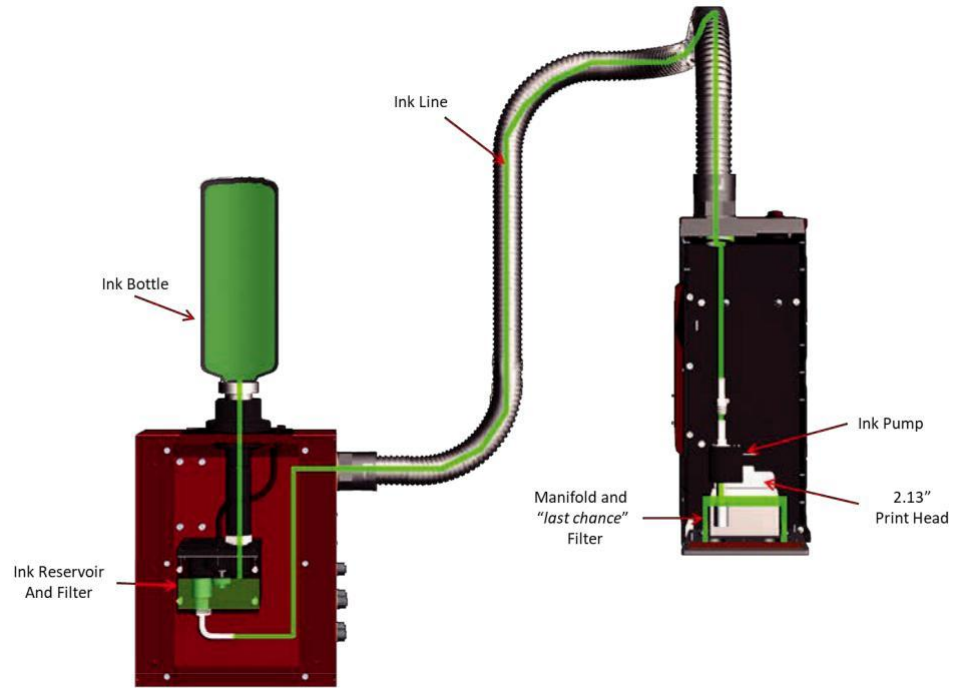

Patent No: US 970773B1

Software that Delivers

The iM2 has multiple capabilities regarding software. It ships with a standard GUI based upon the proven inc.jet software, or alternatively, it can be supplied with a set of tools to enable custom software development.

With the standard GUI, you can be up and running within minutes from design of the basic job template to hitting the Start button and being in production! Bring in databases and easily build a template that fully utilizes the power of dynamic text, bitmaps, counters and so much more. Insert Lot codes, expiry dates and any of over 100 different barcodes.

There are tens of thousands of solid high performing installations of this software installed globally, so there is never a fear of poorly developed software that doesn't have the flexibility and power you need. Proven over and over again to perform.

The software is a proven enterprise level solution that will help you monitor, manage and maximize your print stream. And what's more, its completely free with eternal updates!

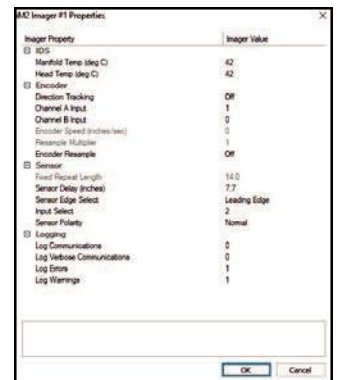

Setup is Simple



Run Screen with full database capability

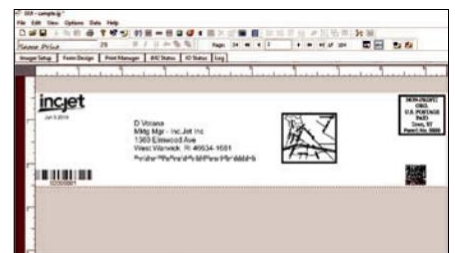

WYSIWYG monitoring

Technical Specifications

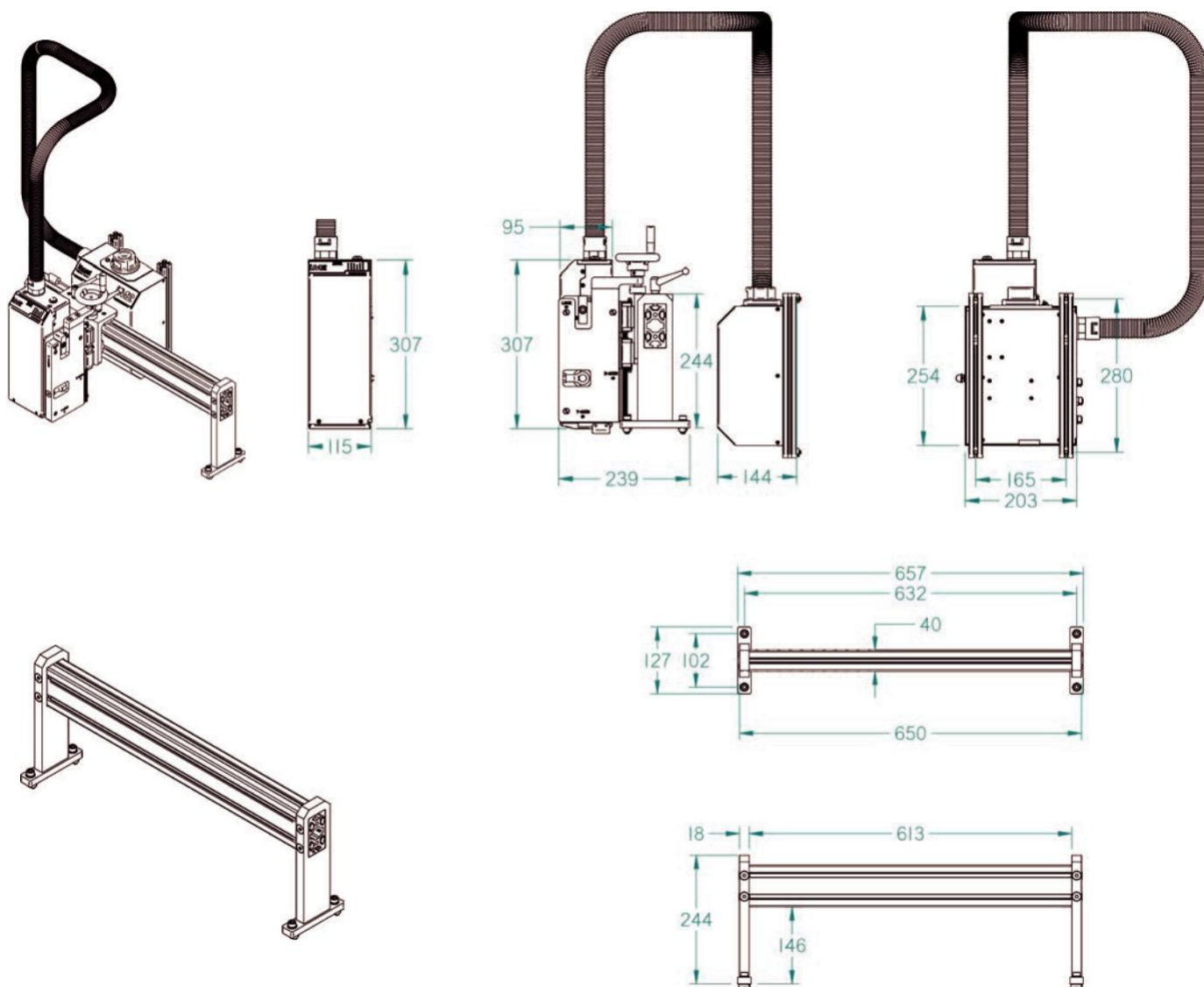

All dimensions in mm

Signal Description	Quantity
Print Width	2.13"/54.1mm
Resolution	600 dpi
No of Drops	1 to 3
Drop Level (1/2/3)	7 pl / 14 pl / 24 pl
Frequency Response	60 kHz
Custom Colors	Yes
Smallest readable font size	3pt

Signal Description	Quantity
Print Speed @ 150dpi	1200 fpm (356 mpm)
Print Speed @ 300dpi	900 fpm (274 mpm)
Print Speed @ 600dpi	450 fpm (137 mpm)
Ink Types	UV
Jetting Technology	Piezo DoD
Communication	Ethernet
Power Requirement	240/115 V AC

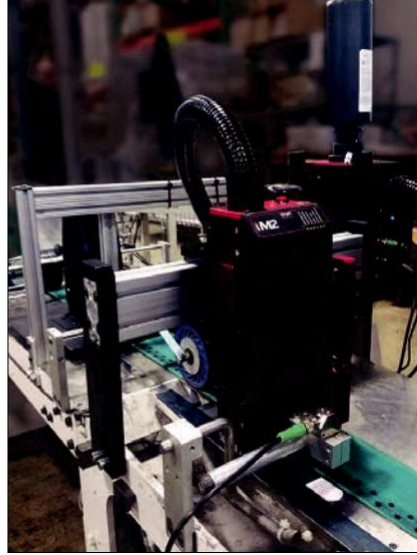

FRANCIS BUEHLER

Francis Buehler AG Bodenstrasse 23, 6403 Küssnacht. Schweiz
www.francisbuehler.ch | info@francisbuehler.ch | Tel. +41 41 850 19 29